

MARMOLERÍA
VIRGEN DE POMPEYA

MARMOLERIA VIRGEN DE POMPEYA



MARMOLERÍA
VIRGEN DE POMPEYA



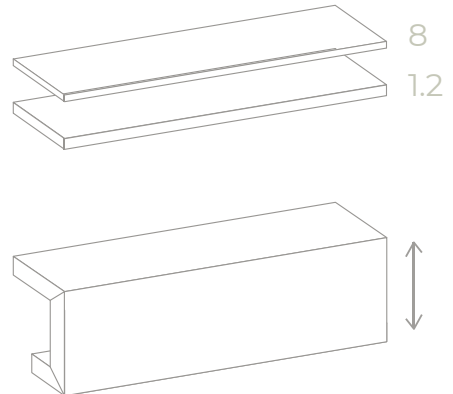
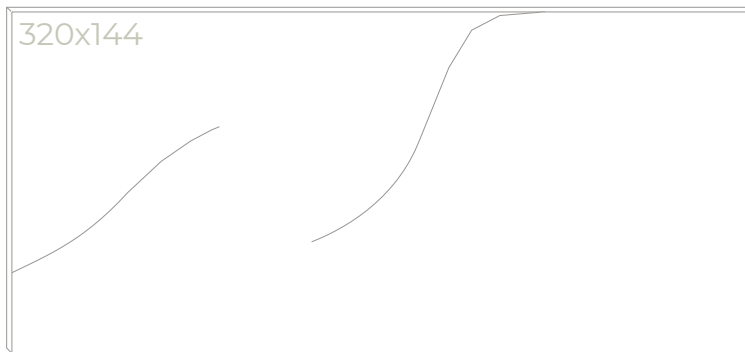

Dekton® es un material compuesto 100% por minerales y utiliza en su fabricación tecnología TSP®, que es un proceso que sinteriza partículas minerales “recreando”, con altísima presión y temperatura, el proceso natural de formación de las rocas pero de manera industrial y en algunas horas. La ultracompactación de este material contribuye de forma significativa a su baja porosidad, convirtiéndolo en un producto de bajo mantenimiento y una larga duración.

ESPEORES

Gracias al tamaño (3200x1440mm) y su variedad en espesores, crecen exponencialmente las posibilidades de diseño en cocinas, baños, fachadas, paredes o pavimentos de alto tránsito.

TEXTURAS

Gracias a la tecnología de fabricación que emplea Dekton®, puede obtener colores y texturas de diversas características, que incluyen sólidos muy puros y cromáticamente homogéneos, materiales con vetas y movimientos muy naturales, o rangos de colores más atrevidos para cualquier mesa o mueble.

PROPIEDADES

<p>ALTAMENTE RESISTENTE AL RAYADO</p>	<p>ALTA RESISTENCIA A LOS RAYOS ULTRAVIOLETAS</p>	<p>MÁXIMA RESISTENCIA AL FUEGO Y AL CALOR</p>	<p>RESISTENCIA AL HIELO Y DESHIELO</p>	<p>RESISTENCIA A LAS MANCHAS</p>	<p>ALTA RESISTENCIA MECÁNICA</p>
<p>RESISTENCIA A LA ABRASIÓN</p>	<p>REDUCIDA ABSORCIÓN DE AGUA</p>	<p>APTO PARA CONTACTO PERMANENTE CON AGUA</p>	<p>ESTABILIDAD AL COLOR</p>	<p>ESTABILIDAD DIMENSIONAL</p>	<p>MATERIAL INCOMBUSTIBLE</p>

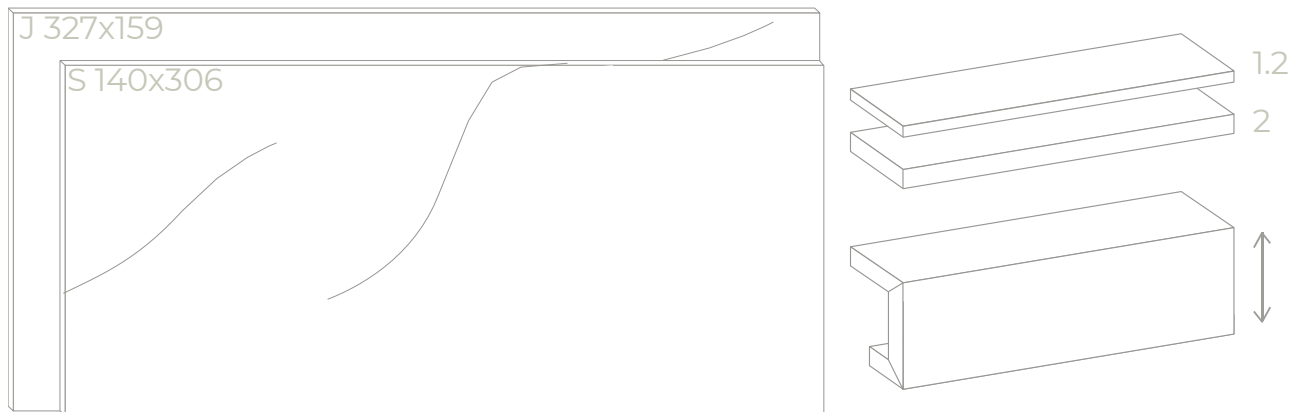

*Medidas proporcionadas en cm.

Líder indiscutible en mesadas desde hace 30 años, Silestone es un producto de la empresa española Grupo Cosentino. Es la única super cie de cuarzo fabricada con 94% de cuarzo natural, lo que le confiere gran solidez y le proporciona las excelentes propiedades de resistencia y durabilidad.

TEXTURAS

Con el objetivo de adaptarse a todos los estilos, Silestone® ofrece diferentes texturas para cualquiera de sus aplicaciones. Pulido, Suede o Volcano son tres posibilidades que hacen que su imaginación vuele y tenga las encimeras, suelos o paredes con la textura que siempre había deseado.

ESPESORES

Las tablas de Silestone® se comercializan en espesores de 1,2 y 2 cm. Además se pueden combinar diferentes piezas para simular cantos de mayor espesor.

➔ PROPIEDADES



**RESISTENTE
A LAS MANCHAS**



**RESISTENTE
AL ÁCIDO**



**RESISTENTE
AL RAYADO**



**RESISTENTE
AL IMPACTO**



**DIFERENTES
TEXTURAS**



**AMPLIA GAMA
DE COLORES**



**CUARZO
NATURAL**

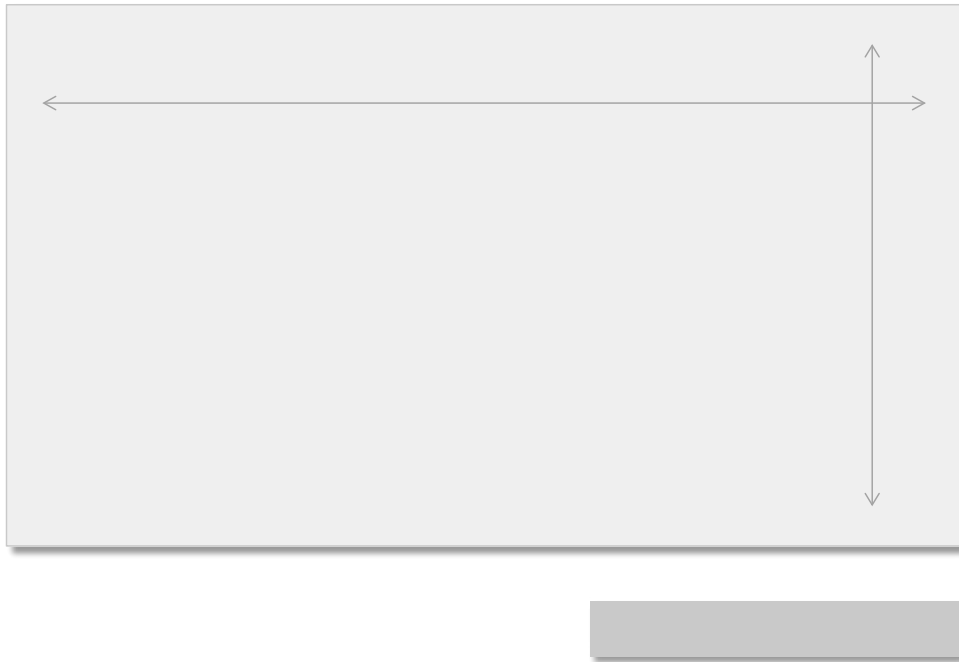

Es una super cie fabricada a partir de una mezcla de minerales de origen calcáreo, pigmentos y resina. Este material ofrece super cies de excepcional belleza con las mismas virtudes y encanto de la piedra natural, con el añadido de la tecnología.
En sus características técnicas lo comparamos con el marmol, tanto en sus resistencias como en su mantenimiento.

APLICACIONES

Debido a su componente de resina, es una material exclusivamente para uso interior, ideal para para revestir paredes, diseñar bachas y mesadas de baño y tapas de mesas (que no sean de uso diario).

Al igual que el marmol, se debe tener especial cuidado para evitar rayas y manchas que perduren.

➤ PROPIEDADES



MÁRMOL

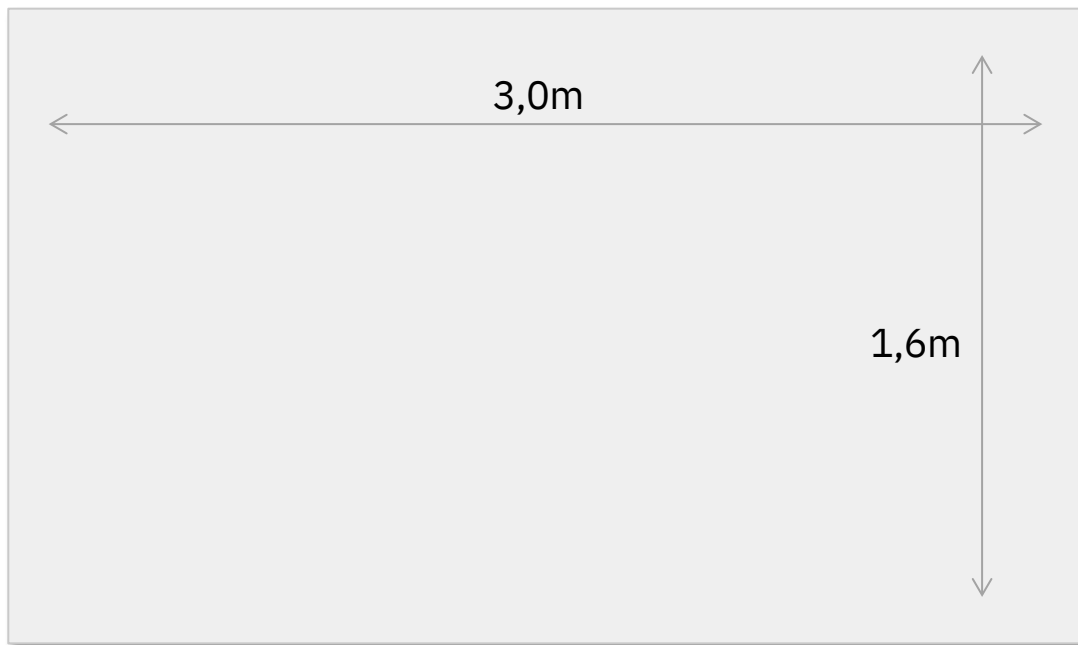

Espesor 20mm

Es una roca metamórfica formada a partir de rocas calizas de dureza media. Sus texturas naturales y su variedad y riqueza cromática son algunas de las características del mármol que lo han hecho uno de los materiales preferidos por interioristas y arquitectos. La tonalidad del mármol se mantiene inalterable con el paso del tiempo, sobre todo si se utiliza en interiores. El resultado son ambientes cálidos que transmiten elegancia y singularidad.

APLICACIONES

Es un material que aporta elegancia y estilo a todos los ambientes, es atemporal y durable; sin embargo, debido a su composición que le otorga una dureza media y una alta porosidad, se utiliza en baños, tapas de mesa revestimientos de pisos y paredes interiores siempre haciendo un uso responsable para evitar manchas y rayas.

➤ APLICACIONES

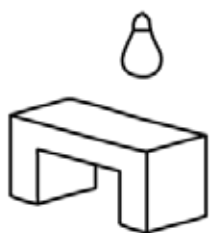

Mesadas de cocina

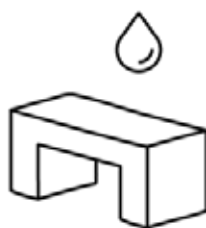

Mesadas de baño

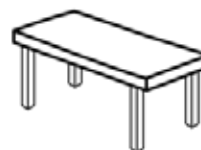

Tapas de mesa



Pisos interiores y exteriores

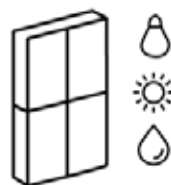

Revestimientos interiores y exteriores



Escaleras

GRANITO

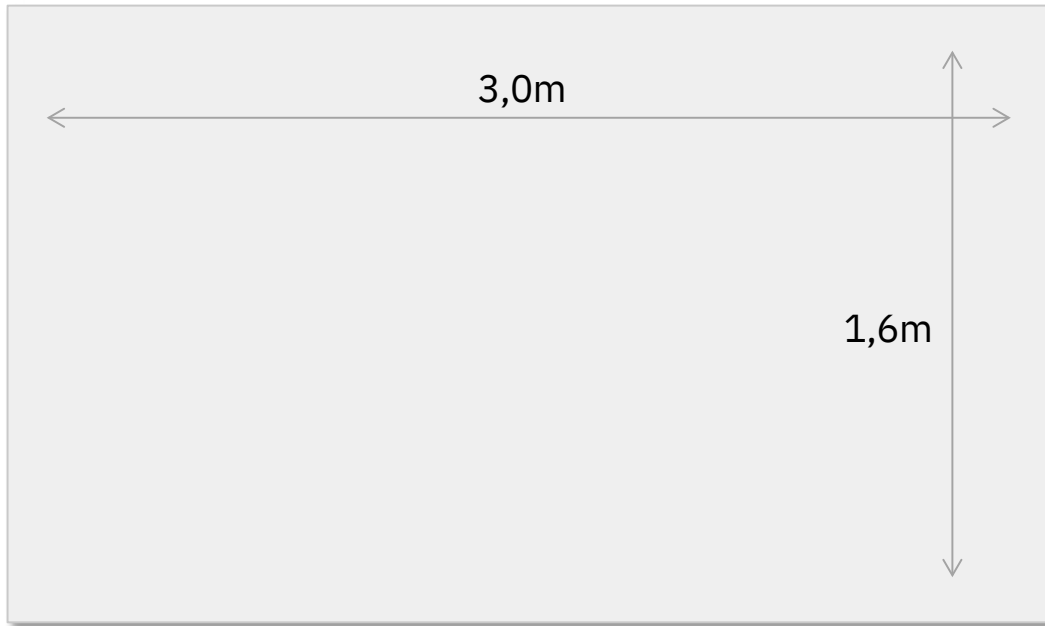

Todos los bloques de piedra son diferentes, por lo cual no podemos establecer un tamaño de placa determinado. Aproximadamente podríamos decir que ronda los 3,1 m x 1,7m. pero suele variar incluso dependiendo el color.



Espesor 20mm

Es un roca ignea compuesta principalmente por feldespato y cuarzo, lo que les proporciona una dureza de media a alta. Su elegancia atemporal y su resistencia son grandes ventajas del granito, que lo convierten en un material perfecto para exteriores e interiores. Con él la autenticidad y la funcionalidad son sinónimo de una belleza innovadora.

APLICACIONES

Son piedras de amplia dureza, que permite someterlas a usos mas intensivos. Son ideales para mesadas de cocina, de baño, revestimientos interiores y exteriores. Su mantenimiento es bajo debido a su resistencia a las rayas y manchas del uso diario.

➤ APLICACIONES

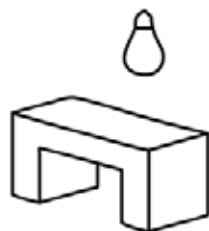

Mesadas de cocina



Mesadas de baño

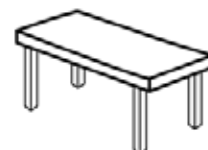

Tapas de mesa



Pisos interiores y exteriores

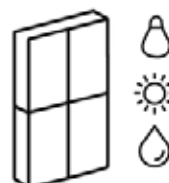

Revestimientos interiores y exteriores



Escaleras

CUARCITA

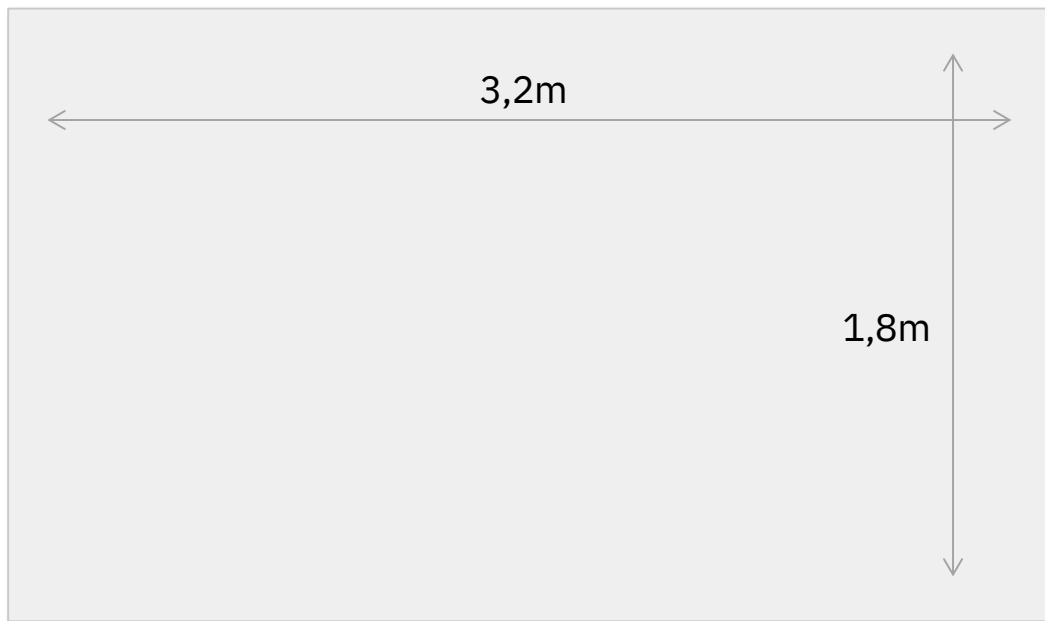

Todos los bloques de piedra son diferentes, por lo cual no podemos establecer un tamaño de placa determinado. Aproximadamente podríamos decir que ronda los 3,2 m x 1,8m. pero suele variar incluso dependiendo el color.

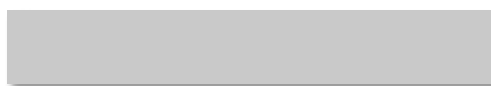

Espesor 20mm

Es una roca metamórfica dura con alto contenido de cuarzo, que presenta en variedades exóticas con tonos y acabados muy apreciados para la arquitectura y el interiorismo, debido a su belleza, porte y durabilidad. Son materiales exóticos con vetas, colores y tonalidades sorprendentes con una fuerza estética magnética. Debido a su composición, presentan además una dureza y resistencia lo que las convierte en un material único.

APLICACIONES

Gracias a su gran dureza, puede aplicarse tanto en interior como exterior y tiene un bajo mantenimiento. Es ideal para mesadas de cocina, mesadas de baño, tapas de mesa y pisos y revestimientos de diversas superficies.

➤ APLICACIONES

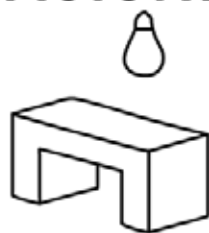

Mesadas de cocina

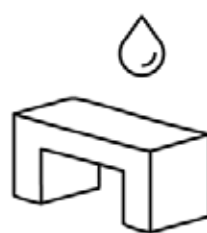

Mesadas de baño

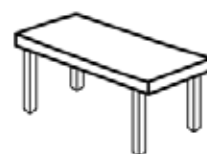

Tapas de mesa



Pisos interiores y exteriores

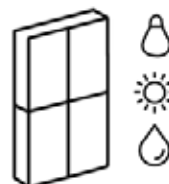

Revestimientos interiores y exteriores



Escaleras

SILESTONE Y DEKTON

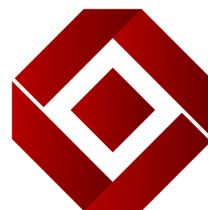

**MARMOLERÍA
VIRGEN DE POMPEYA**



BLANCOS



SIL. BLANCO NORTE  

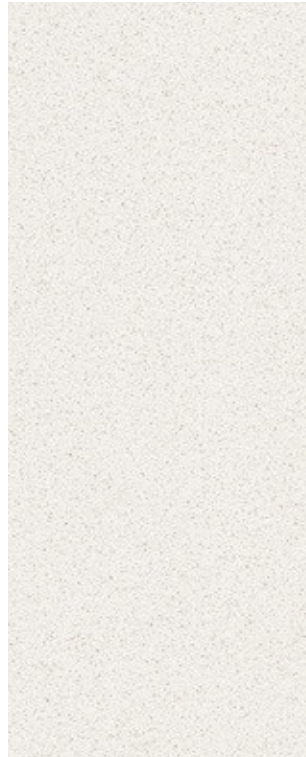

SIL. WHITE STORM  

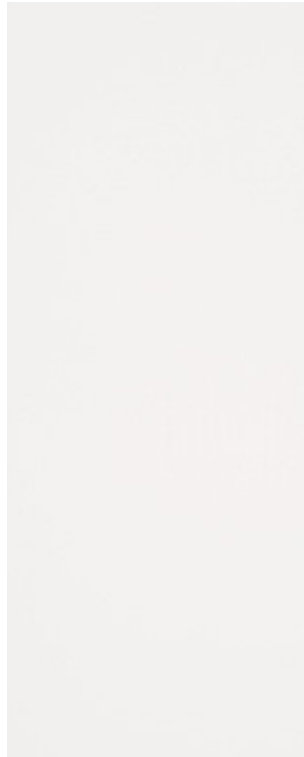

SIL. MIAMI WHITE 



SILESTONE YUKON 



SIL. BLANCO STELLAR 



SIL. BLANCO ZEUS  



DEKTON ZENITH 

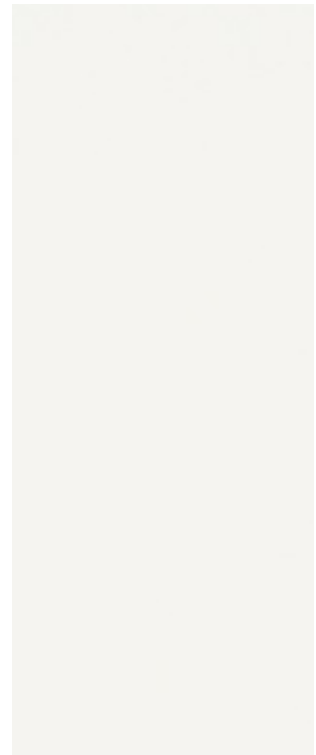

DEKTON HALO 

BLANCOS VETEADOS



SILESTONE LYRA



SIL. PEARL JASMINE



SIL. CLASSIC CALACATTA



SIL. CALACATTA GOLD



DEKTON OPERA



DEKTON ENTZO



DEKTON AURA



DEKTON NATURA





DEKTON OLIMPO



DEKTON BERGEN

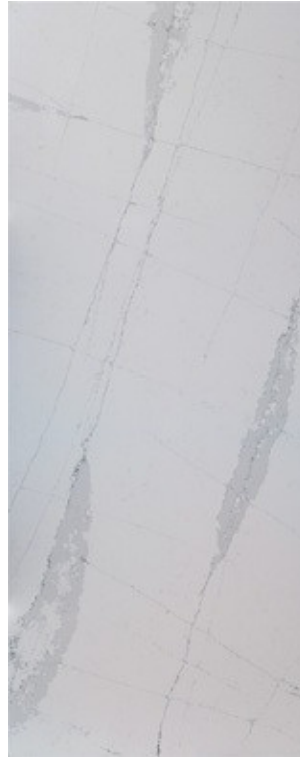

SIL. ETHER DUSK

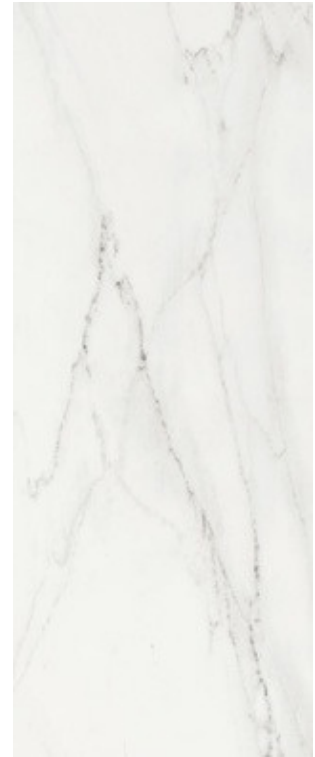

DEKTON REM

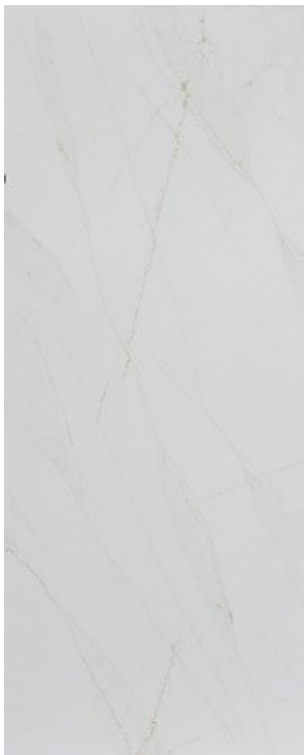

SIL. ETHER GLOW

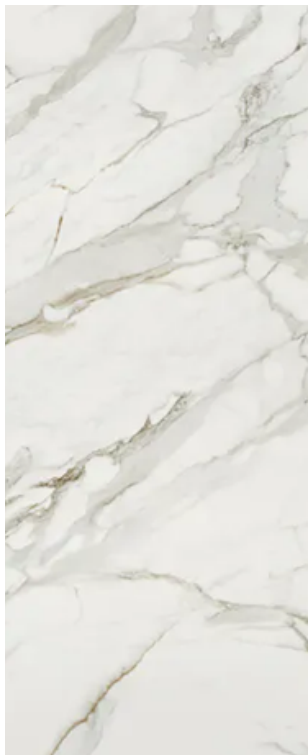

DEKTON DAZE



DEKTON MORPHEUS

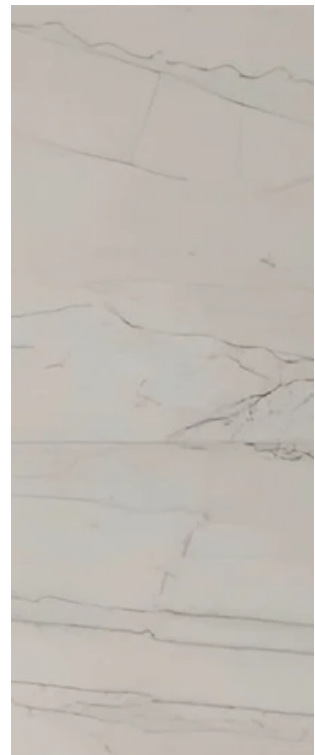

DEKTON NEURAL





DEKTON VIGIL

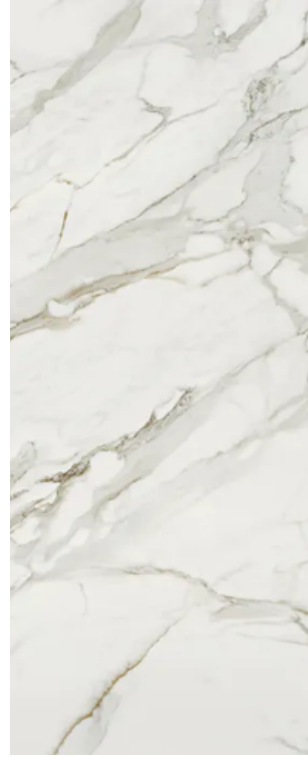

DEKTON LUCID



DEKTON AWAKE



GRISES

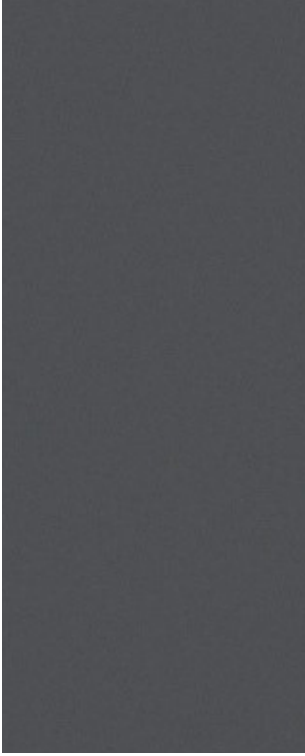

SILESTONE MARENGO ✨



SILESTONE NIEBLA ✨



SILESTONE CHARCOAL ✨



SILESTONE KENSHO ✨



SIL. ALUMINIO NUBE ✨



DEKTON KEON



DEKTON BROMO



DEKTON VERA



SIL. GRIS EXPO



SIL. DESERT SILVER



MARRONES



SILESTONE NOKA



SILESTONE UNSUI



DEKTON KIRA



DEKTON TRILIUM

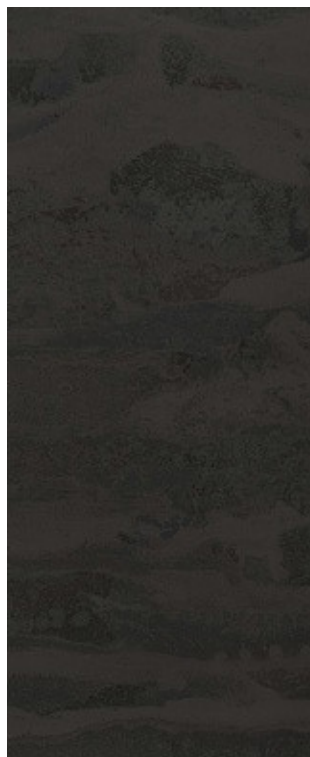

DEKTON RADIUM



DEKTON KORSO*



DEKTON VALTERRA



SIL. ROUGI LENA



BEIGE



DEKTON DANAЕ



DEKTON NILIUM



NEGROS



SIL. NEGRO TEBAS

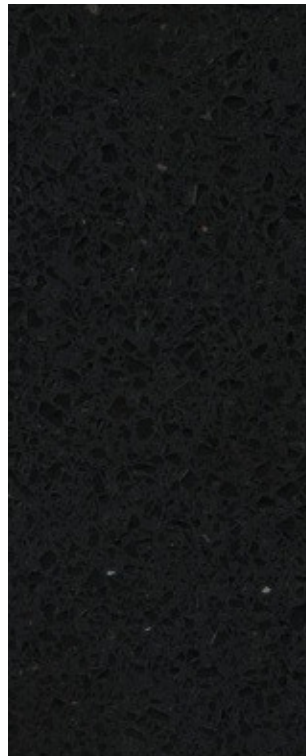

SIL. NEGRO STELLAR

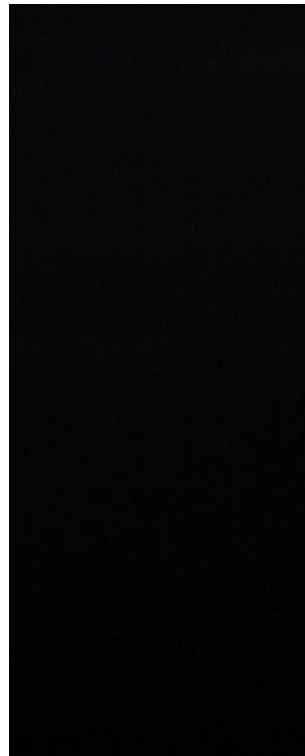

DEKTON DOMOOS



DEKTON SIRIUS



BEIGE



DEKTON DANAЕ



DEKTON NILIUM



NEGROS



SIL. NEGRO TEBAS

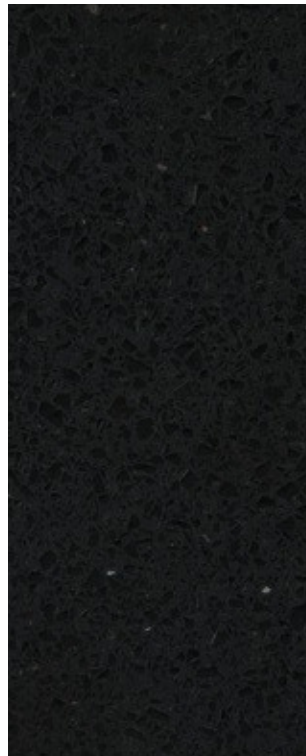

SIL. NEGRO STELLAR

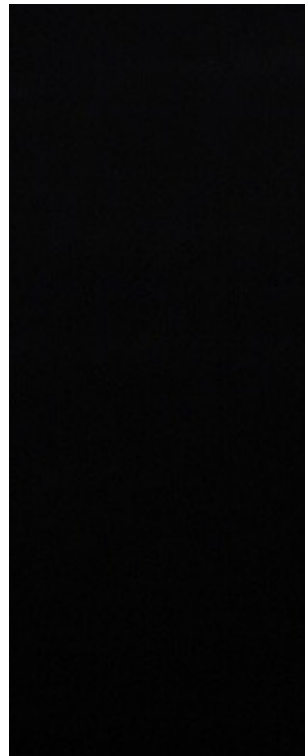

DEKTON DOMOOS



DEKTON SIRIUS



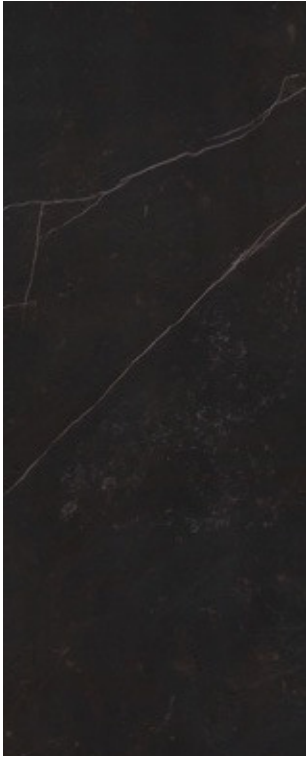

DEKTON KELYA



SIL. MARQUINA



SILESTONE NOIR



DEKTON SPECTRA



DEKTON SOMNIA



DEKTON LAURENT



DEKTON FOSSIL



ROJOS



SIL. ARCILLA RED

VERDES



SIL. POSIDONIA GREEN

AZULES

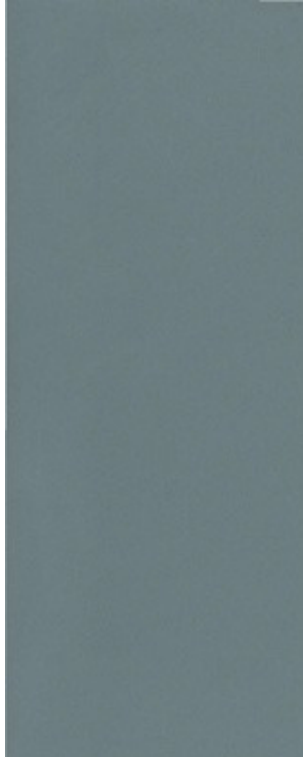

SIL. CALA BLUE



MÁRMOLES Y MARMOTECH



BLANCOS/BLANCOS VETEADOS

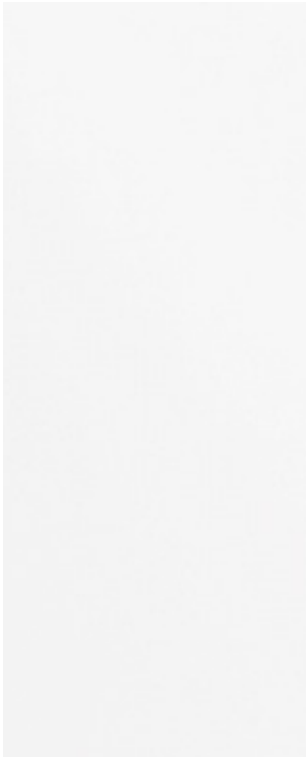

MARMOTECH BLANCO NEVE 



MARMOTECH STATUARIO MILANO 



MARMOTECH CALACATTA MILANO 



BLANCO ROYAL  



CARRARA CD  



BLANCO PERLINO  

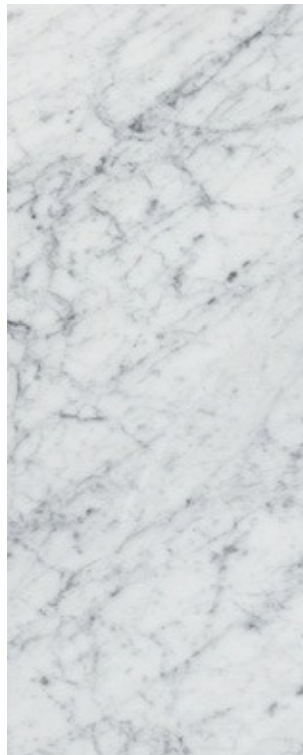

CARRARA  

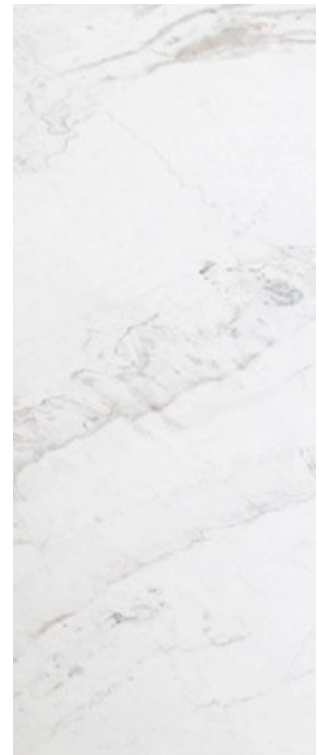

BLANCO GRIEGO 

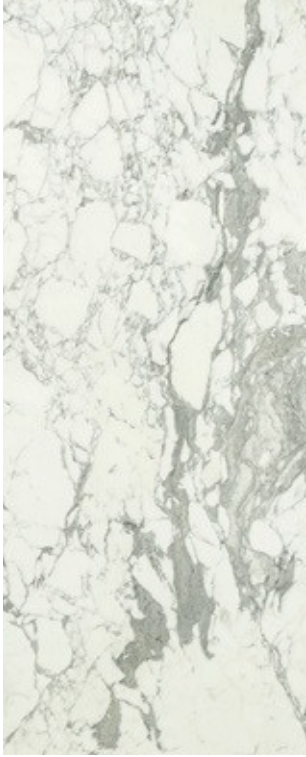

ARABESCATO



ESTATUARIETTO



GOFLAN SILVER

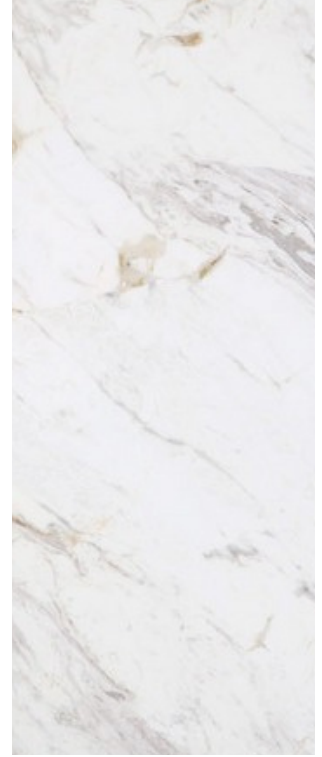

BLANCO GRIEGO ORO

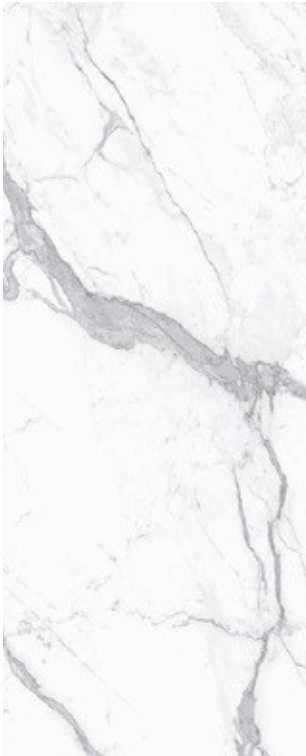

ESTATUARIO

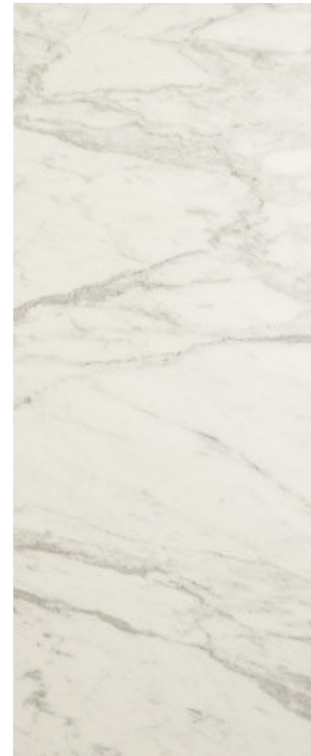

CALACATTA



CALACATTA EXTRA



BLANCO GRIEGO EXTRA





ESTATUARIO EXTRA

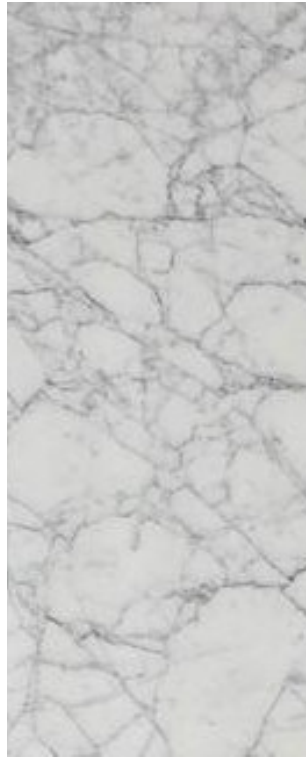

ARABESCATO EXTRA



BEIGES



MARMOTECH BEIGE
ARENA

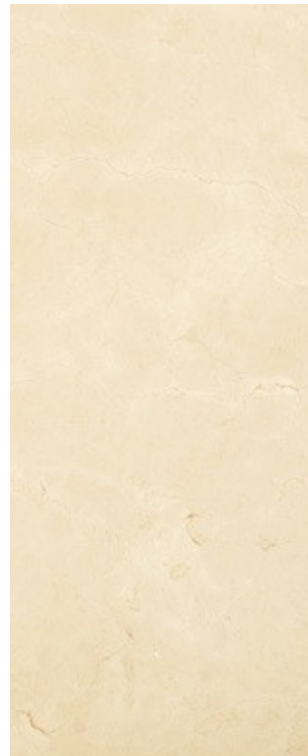

CREMA MARFIL



BOTICCINO

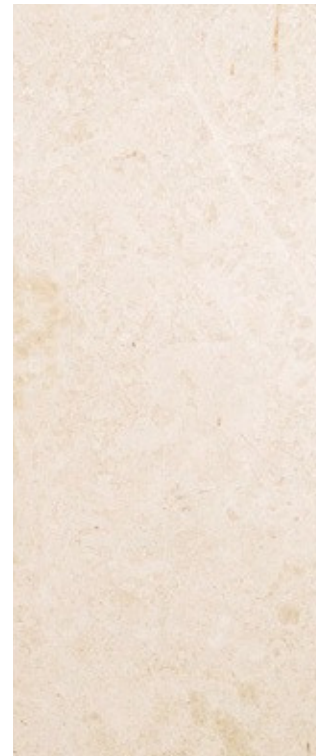

DESERT CREAM





JURA BEIGE



PERLADO

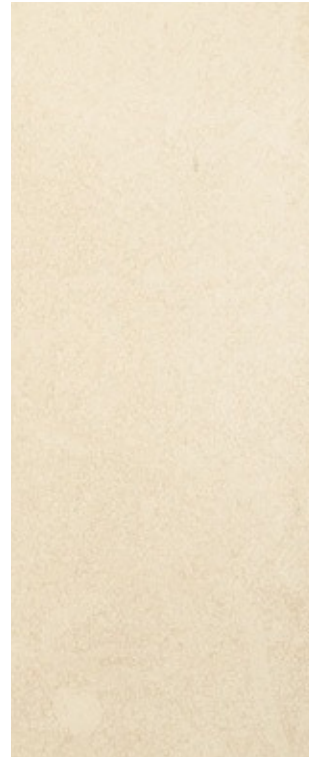

GALALA



ONYX AMBRA

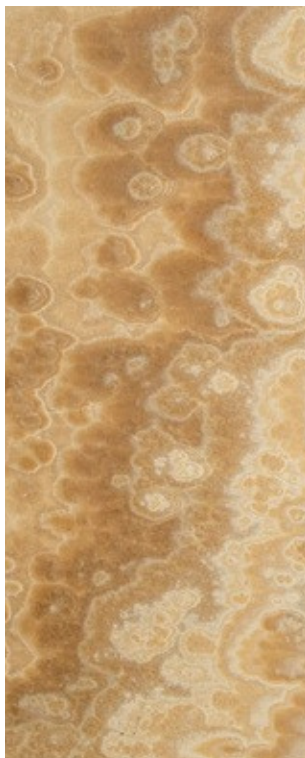

ONYX MIELE



GRISES



MARMOTECH STAR GREY 



TUNDRA GREY  



EMPERADOR GREY  

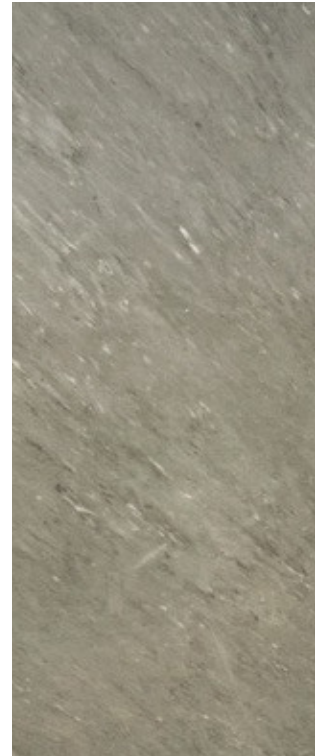

BARDIGLIO IMPERIAL  



ARABESCATO GRIGIO  

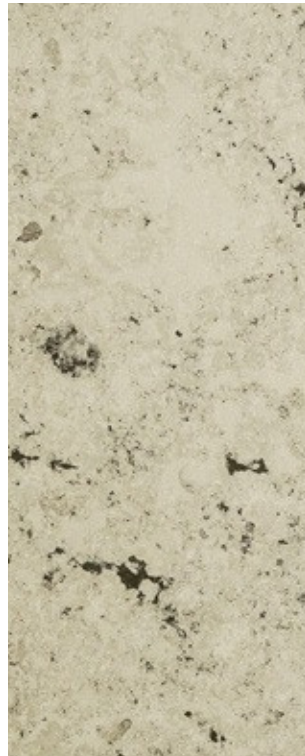

PIEDRA JURA GREY  



INVISIBLE GREY  

TRAVERTINOS





T. TURCO AL AGUA  



T. TURCO A LA VETA  



TRAVERTINO SILVER  

MARRONES/ROJOS



MARRÓN EMPERADOR  



MARRÓN BOSQUE 



GRAPHITE BROWN  

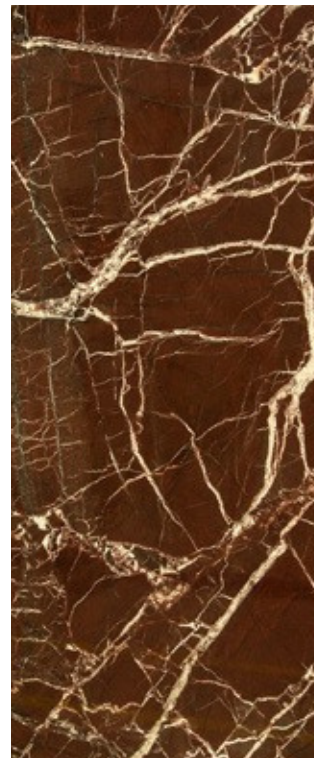

ROSSO LEVANTO  



SAINT LAURENT



ONYX STRIATO



DESERT BROWN



VERDES

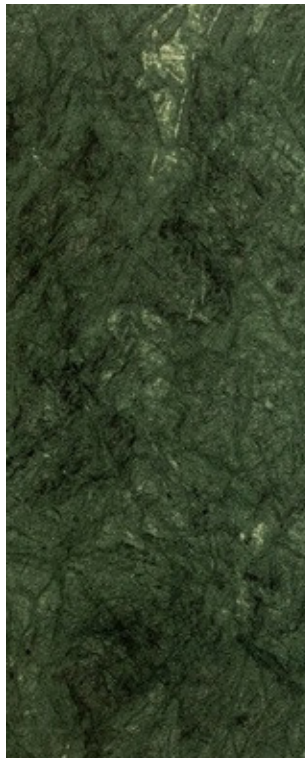

VERDE ORIENTAL

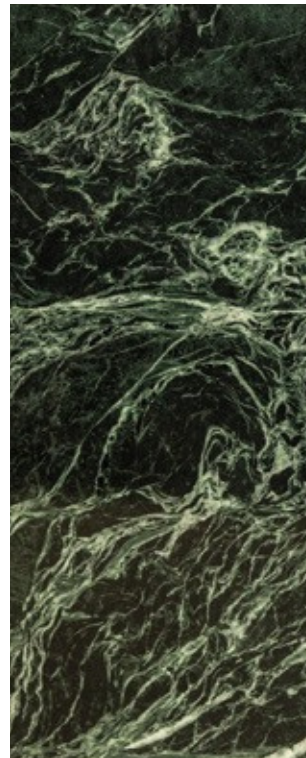

VERDE REMIGGIATO



VERDE BOSQUE



ONYX LIGHT GREEN



NEGROS



NEGRO MARQUINA



BLACK FOREST

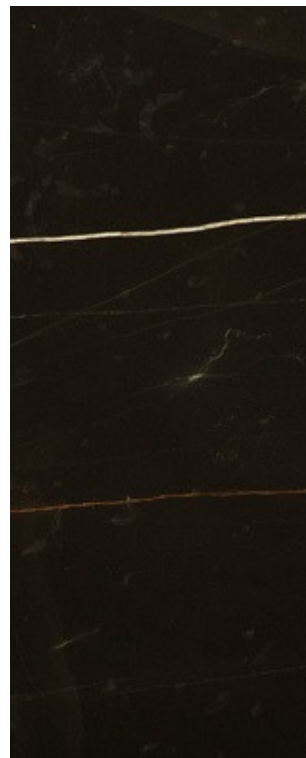

SAHARA NOIR

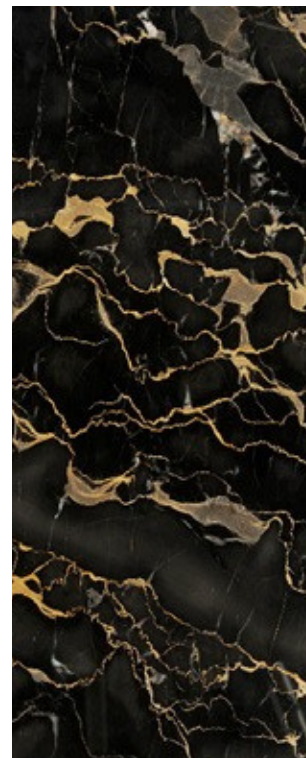

PORTORO



GRANITOS Y CUARCITAS

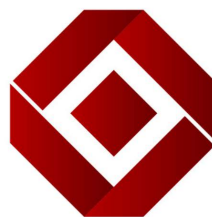

MARMOLERÍA
VIRGEN DE POMPEYA





GRANITOS

BLANCOS



BLANCO FORTALEZA  
20mm



BLANCO DALLAS  
20mm



KASHMIR WHITE  
20mm



SPLENDOR WHITE  
20mm



BIANCO ANTICO  
20mm



ALPINUS  
20mm

GRISES



GRAPHITO



PORFIDO



VERDES / AZULES



VERDE UBATUBA



VOLGA BLUE



AZUL LABRADOR



NEGROS



NEGRO BRASIL 1RA



VIA LACTEA



NEGRO ABSOLUTO

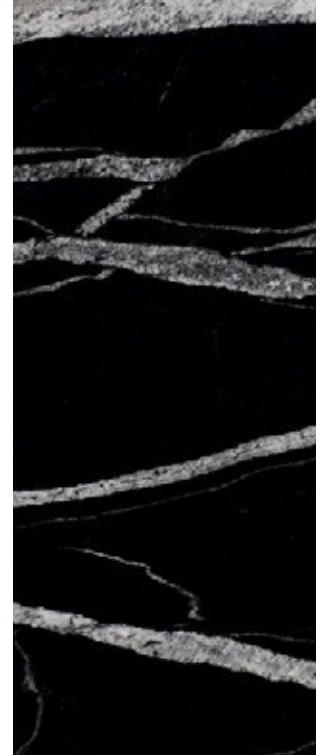



MAORI





CUARCITAS

BLANCOS VETEADOS

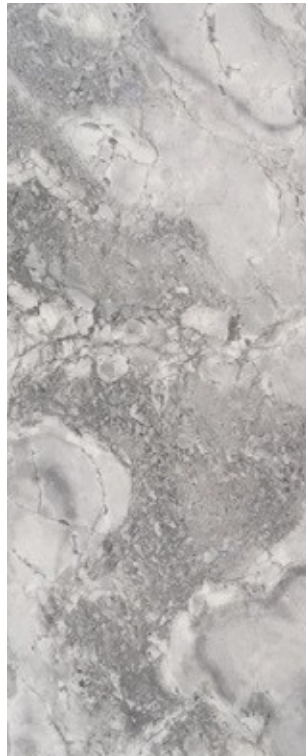

CALACATTA QUARZ  



SUPER WHITE  

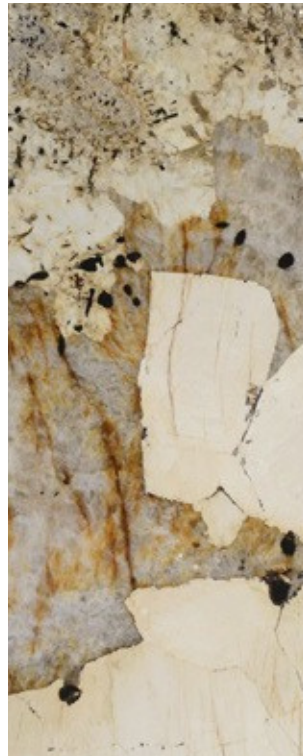

PATAGONIA  

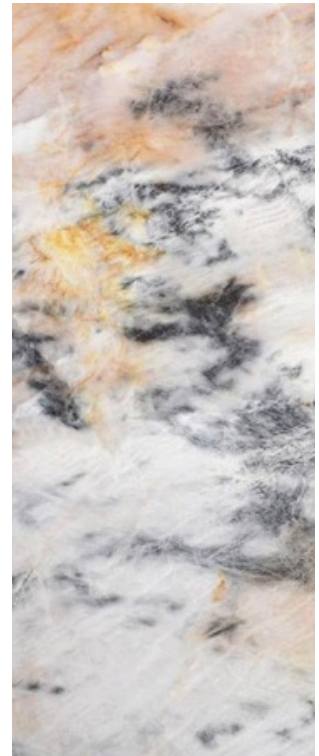

ROSEBLUE  



CALACATTA BOHEMIA  



SALVATORE  

AZULES/VERDES



VERDE GAYA



BLUE ROMA



LEMURIAN BLUE



ESMERALD GREEN

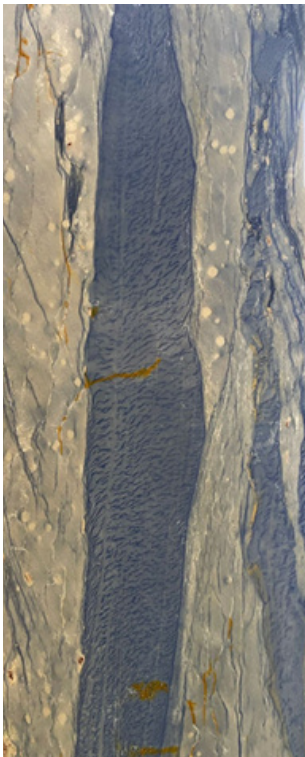

AZUL IMPERIALE



—
AZULES/VERDES

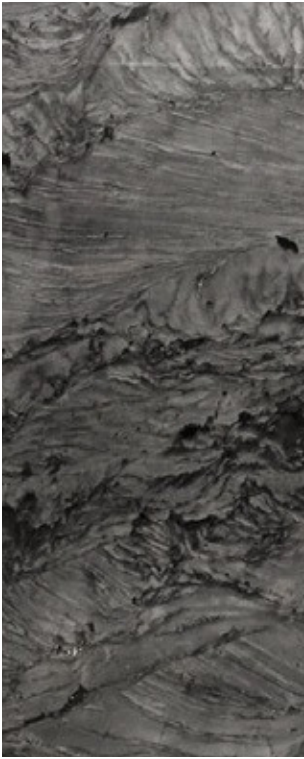

LONDON ADAMANTIUM  





MICHELANGELO  

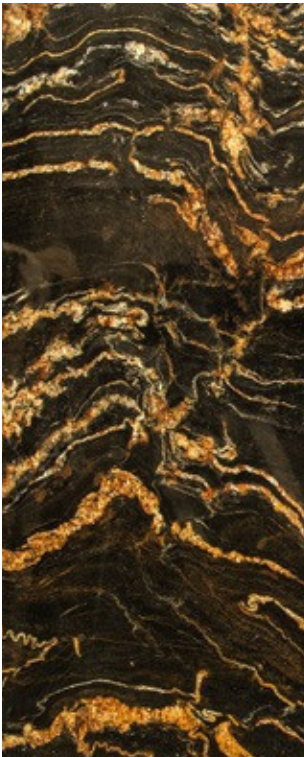

COSMOPOLITAN 

NEGROS



BLACK TAURUS  

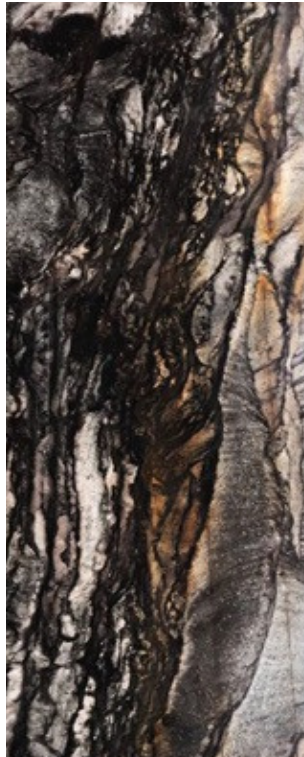

SANDALUS 

BEIGES/MARRONES

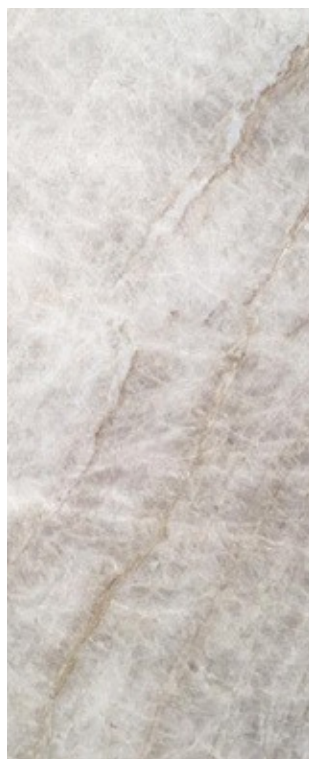

TAJ MAHAL



LUMIX



ROMA IMPERIAL



OUSE



JACARANDÁ



SEQUOIA BROWN



NACARADO



FUSION



TEL. 4139.9000
ventas@canterasdelmundo.com

Todas las imágenes son meramente ilustrativas.

 PULIDO  LEATHER

NEOLITH



Neolith® es una superficie compacta sinterizada, compuesta 100% en base a materiales naturales. La tecnología de sinterización replica en cuestión de horas el proceso por el cuál se crean los pétreos de forma natural a lo largo de miles de años.

Gracias a su gran formato y características físico mecánicas, este tipo de producto es idóneo para un sinfín de aplicaciones interiores y exteriores en el área comercial y residencial: Mesadas de cocina, pisos, revestimiento de paredes, fachadas ventiladas, revestimiento de muebles, etc.

La imaginación es el único límite que tiene Neolith®.

Neolith



Calor



Altas Temperaturas

Resistencia a fuego o calor extremo.



Manchas



Limpieza

Resistencia a agentes químicos en productos de limpieza.



Impacto



Impacto

Resistencia a los golpes.



Rayado



Rayado

Resistencia al rayado y abrasión por la dureza de los materiales.



U.V.



Resistencia U.V.

Resistencia a la decoloración por exposición a rayos ultra violeta.

Neolith Pulido



Calor



Altas Temperaturas

Resistencia a fuego o calor extremo.



Manchas



Limpieza

Resistencia a agentes químicos en productos de limpieza.



Impacto



Impacto

Resistencia a los golpes.



Rayado



Rayado

Resistencia al rayado y abrasión por la dureza de los materiales.



U.V.



Resistencia U.V.

Resistencia a la decoloración por exposición a rayos ultra violeta.

Todas las aplicaciones de Neolith



Mesadas de cocina



Mesadas de baño



Revestimientos Interiores



Pisos Interiores



Mesas exteriores



Pisos exteriores



Revestimientos exteriores



Abu Dabhi



Layla



Amazonico



Himalaya Cristal



Sumer Dala



Artic White

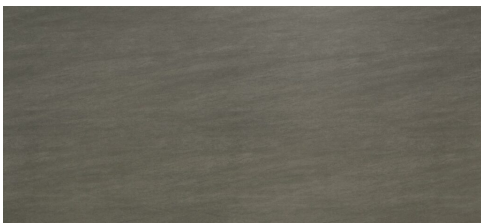

Basalt Grey

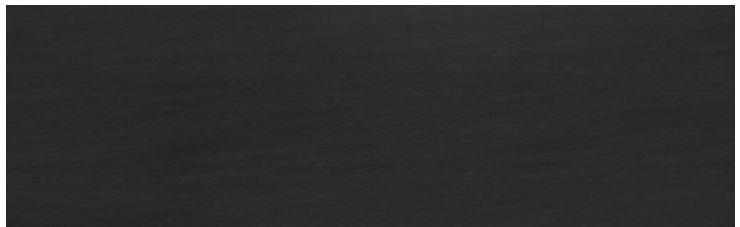

Basalt Black



Beton

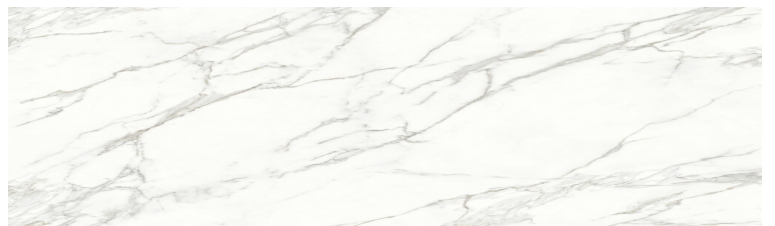

Calacatta C01



Estaturario E01



Iron Coper



Nero

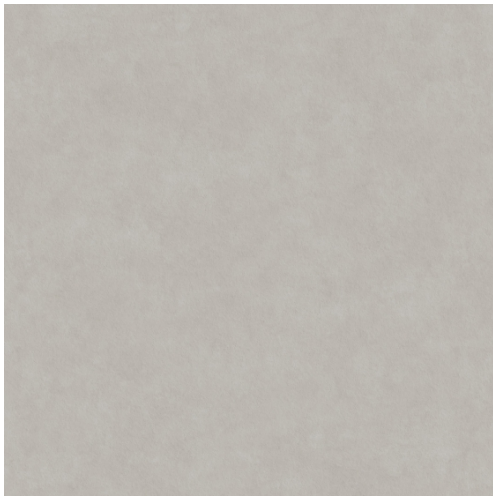

Pietra di Luna

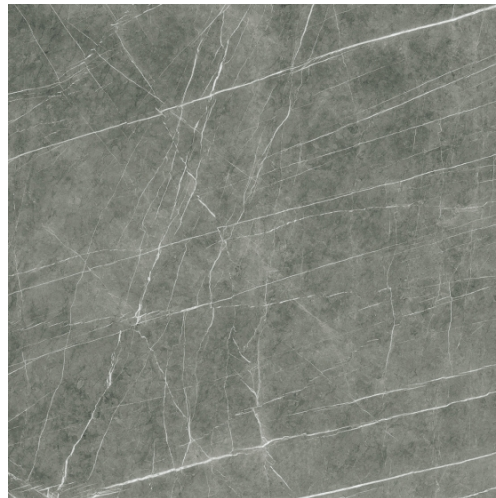

Zaha Stone

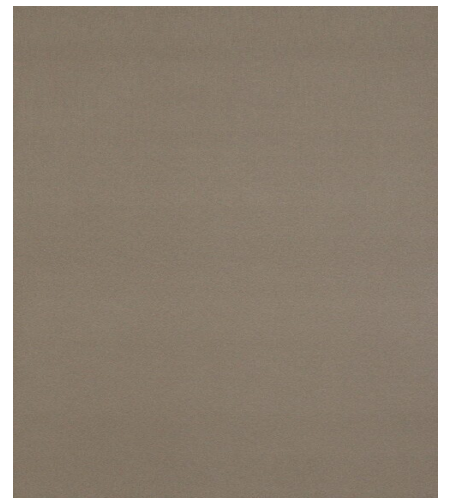

Barro



Calacatta Luxe

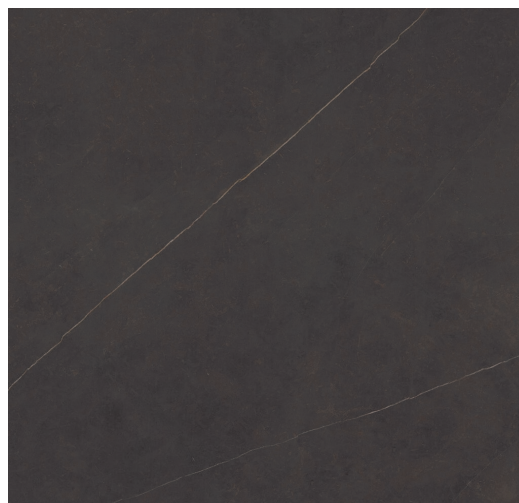

Calatorao



Cement

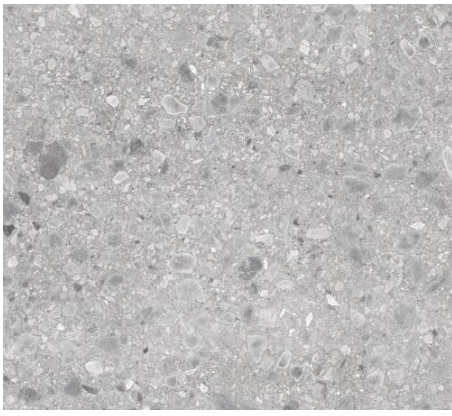

Ceppo Di Gress



Iron Corten



Iron Cooper



Iron Grey

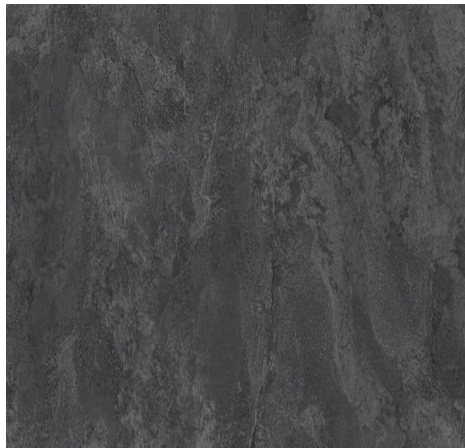

Krater



Mont Blanc



Nero Zimbabwe

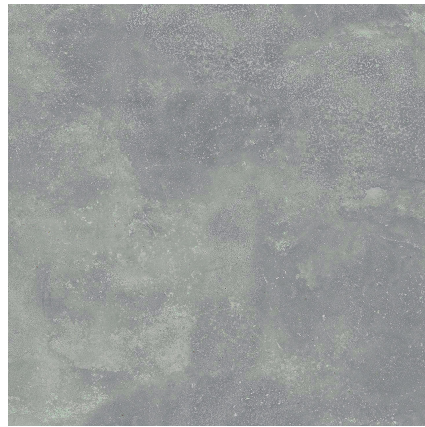

New york

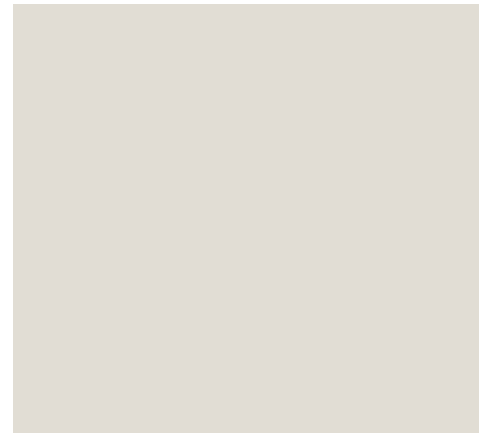

Perla

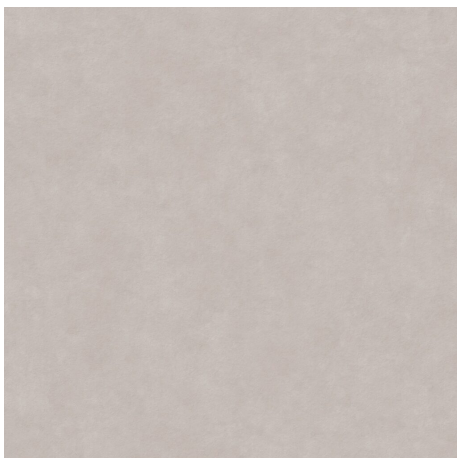

Pietra di Luna



Pietra di Osso

PURA STONE



Purastone® es una superficie de cuarzo premium con características únicas: alta resistencia a rayas y manchas, fácil de limpiar y de instalar. Es de alta durabilidad, por eso es la única en el mercado con 25 años de garantía con respaldo local.

Purastone® es una superficie apta para mesadas de cocina y baño y para aplicaciones de uso comercial (barras, mostradores, etc).



Calor



Altas Temperaturas

Resistencia a fuego o calor extremo.



Manchas



Limpieza

Resistencia a agentes químicos en productos de limpieza.



Impacto



Impacto

Resistencia a los golpes.



Rayado



Rayado

Resistencia al rayado y abrasión por la dureza de los materiales.



U.V.



Resistencia U.V.

Resistencia a la decoloración por exposición a rayos ultra violeta.



Concrete

Purastone



Greyge

Purastone



Gris Zen

Purastone



Negro Glitter

Purastone



Statuario

Purastone



Basaltina

Purastone



Bianco Luxe

Purastone

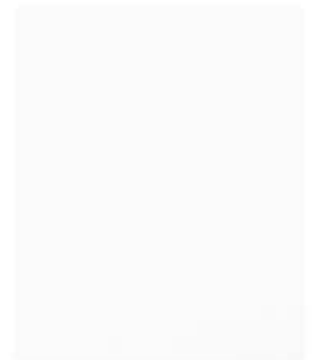

Blanco Icon

Purastone





Blanco Nube
Purastone



Blanco Paloma
Purastone



Calacatta Gold
Purastone



Cemento
Purastone



Gris Fossil
Purastone



Pórfido Gris
Purastone



Terrazzo White
Purastone



Bianco Silver
Purastone



Blanco Cana
Purastone



Blanco Glitter
Purastone



Concrete Dark
Purastone



Crema Pisa
Purastone



Negro Betun
Purastone



Noir
Purastone



Pura Statuarietto
Purastone



Venatino
Purastone





Negro Marquina

Purastone



Gris Topo

Purastone



Calacatta Borghini

Purastone



Calacatta clásico

Purastone



Estuario Venato

Purastone



Arabescato cervairole

Purastone



Calacatta Antico

Purastone



Invisible Grey

Purastone



Arabescato venatino

Purastone



SAT SOFT

Purastone



BLUE SOFT

Purastone



Brick

Purastone



PINK SOFT

Purastone



Nuevo espesor de 12 mm

De formato jumbo pero con 12 mm de espesor

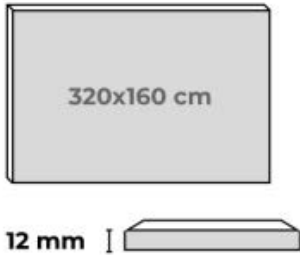

PURASTONE®



6

Arabescato Cervaiolo

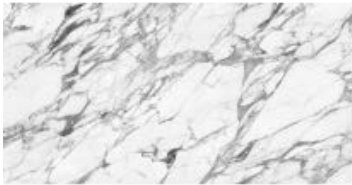

Con acentuadas vetas negras y grises sobre un fondo blanco, genera un atrapante patrón en forma de óvalos.

Terminación

Pulido

Espesores

12

Book match



7

Arabescato Venatino



Atemporal y elegante.
Presenta delgadas vetas que convergen sobre una base blanca de manera continua.

Terminación

Pulido

Espesores

12

Book match



8



Calacatta Antico



Su intrincado patrón combina fuertes líneas oscuras, con notas doradas. Como su nombre lo indica, es una reminiscencia al pasado.

Terminación

Pulido

Espesores

12

Book match



9



Calacatta Borghini



Un diseño orgánico que ejemplifica su aspecto natural. De acuerdo a su combinación, logra un efecto audaz, o sutilmente atractivo.

Terminación

Pulido

Espesores

12

Book match



10



Calacatta Clásico



Tradicional en su belleza, es buscado por su elegante estética. Evoca armonía y equilibrio.

Terminación

Pulido Mate

Espesores

12

Book match



11



Estatuario Venato

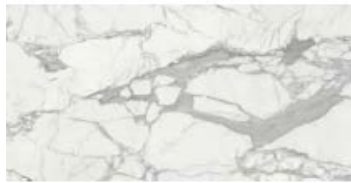

Imponente diseño sobre un sólido fondo blanco puro, homogéneo y atractivo

Terminación

Pulido

Espesores

12

Book match



12



Elegido por la naturaleza

Pura Smart* es la nueva colección de Purastone inspirada en la selección natural de los mármoles más finos

PURAsmart+



Arabescato Cervairole



Arabescato Venatino



Calacatta Antico



Calacatta Borghini



Classic Calacatta

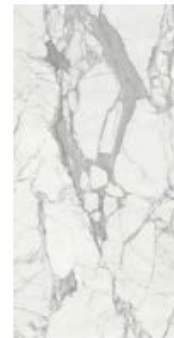

Estatuario Venato



Invisible Grey

PURASTONE®

